

Sorrell SNS-7

HIPERBIPE

Konstruktion: Hilmar Lange



Anleitung zum Aufbringen
der Folienplot-Aufkleber

*Instructions for applying
the foil plot stickers*

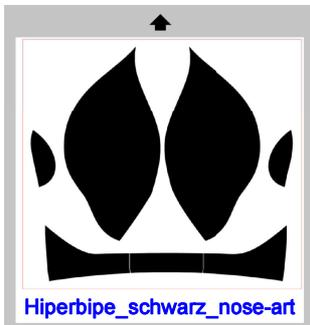

Empfehlung für Klebefolie:
Oracal 751C

verwendete Farbtöne

dunkelgrau: 713 Eisengrau
(entspricht RAL 7012)

hellgrau: 074 Mittelgrau
(entspricht RAL 7042)

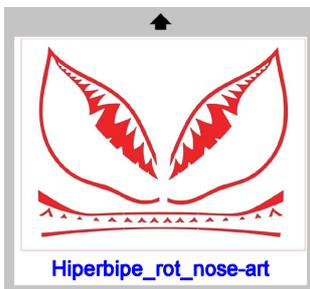
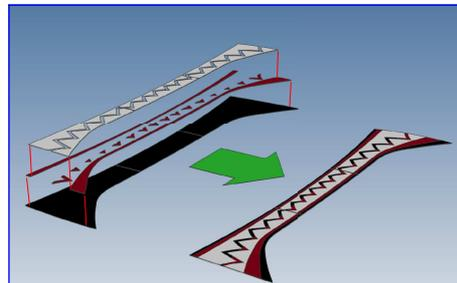

rot: 030 Dunkelrot
(entspricht RAL 3003)

sowie 070 Schwarz
(entspricht RAL 9017)

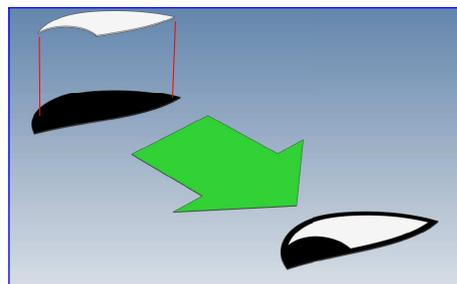
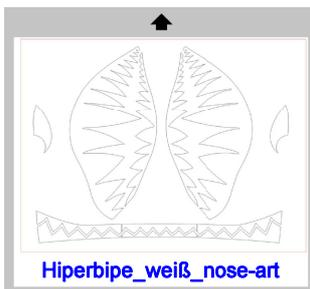
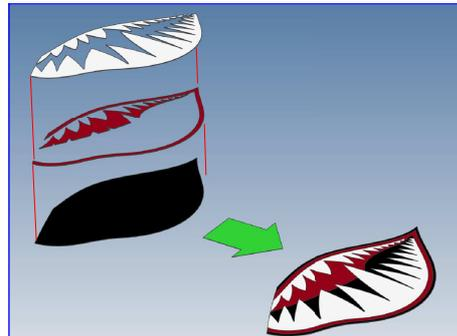



Hiperbipe_dunkelgrau_
Rumpfseite-rechts

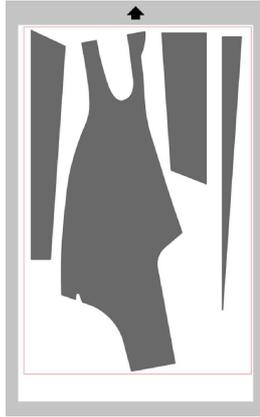

Hiperbipe_dunkelgrau_
Rumpfseite-links

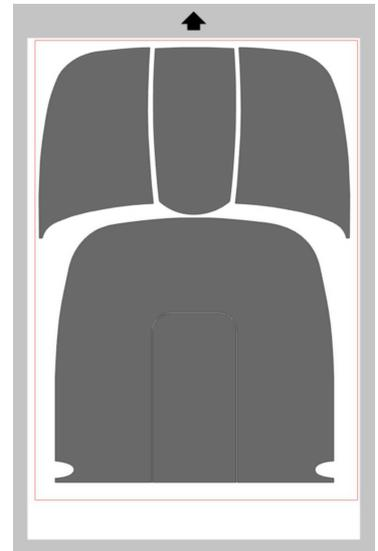
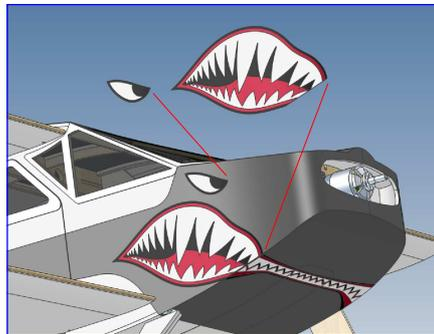
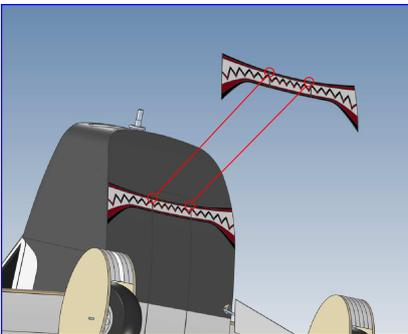
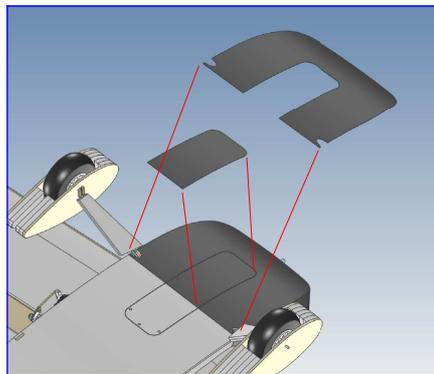
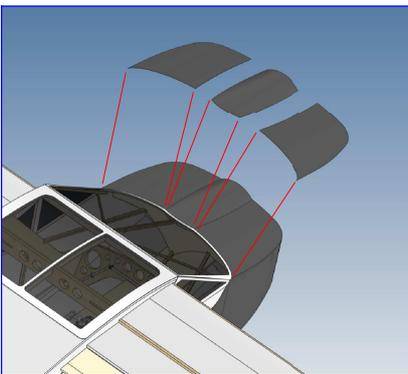
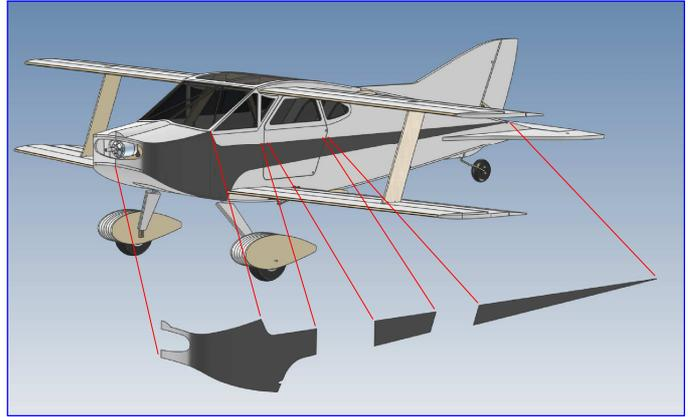

Hiperbipe_dunkelgrau_
Motorhaube-oben

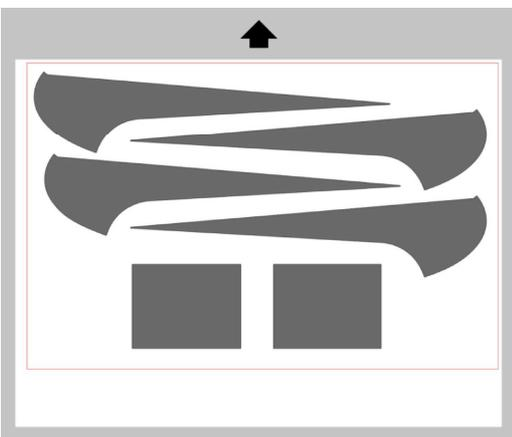

Hiperbipe_dunkelgrau_
Radschuhe

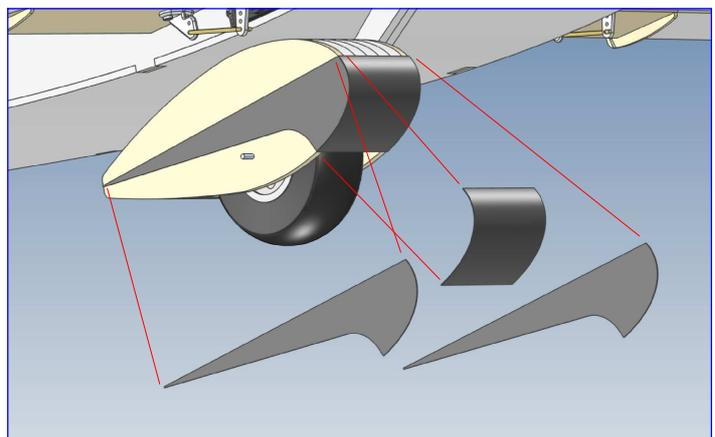

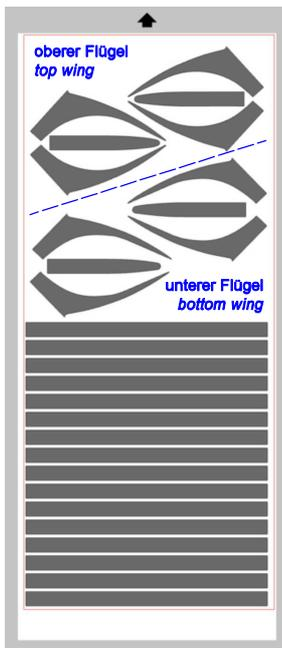

Hiperbipe_dunkelgrau_
Flügelstreifen

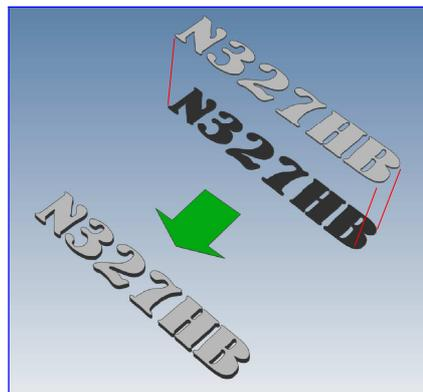
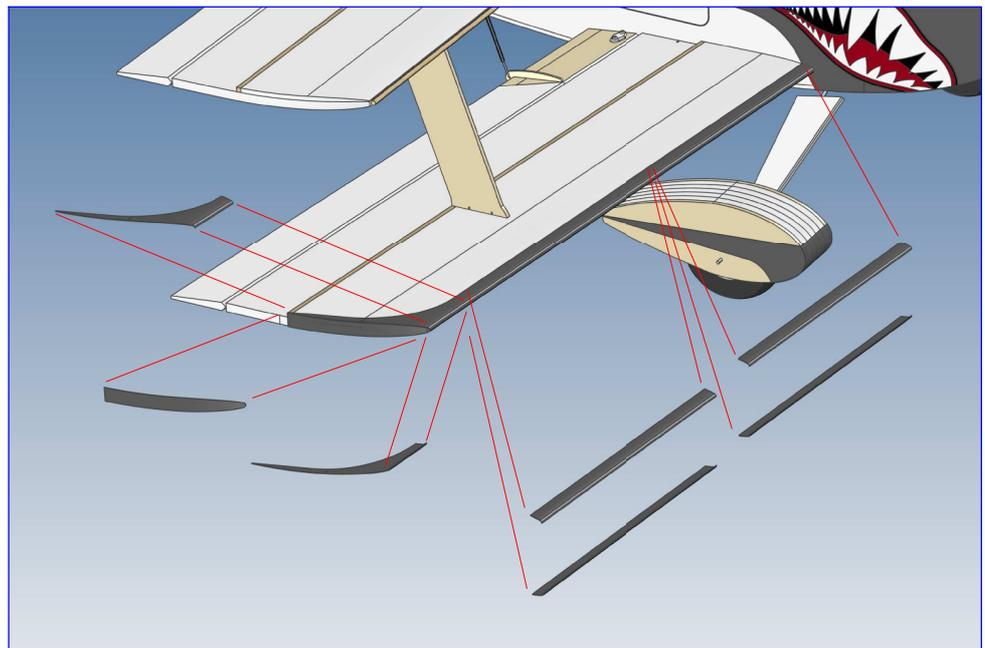

Hiperbipe_schwarz_
Kennung_Schatten

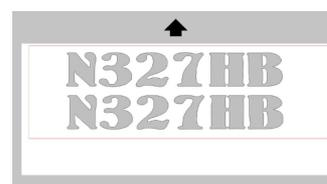

Hiperbipe_hellgrau_
Kennung

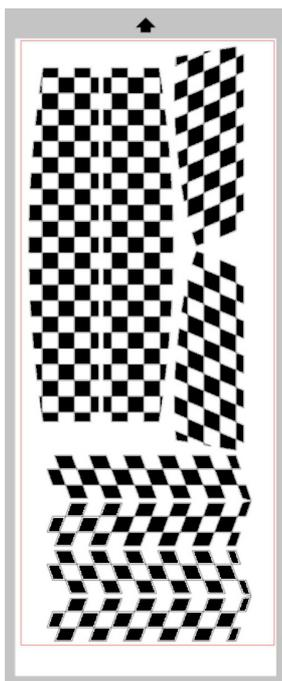

Hiperbipe_schwarz_Karomuster

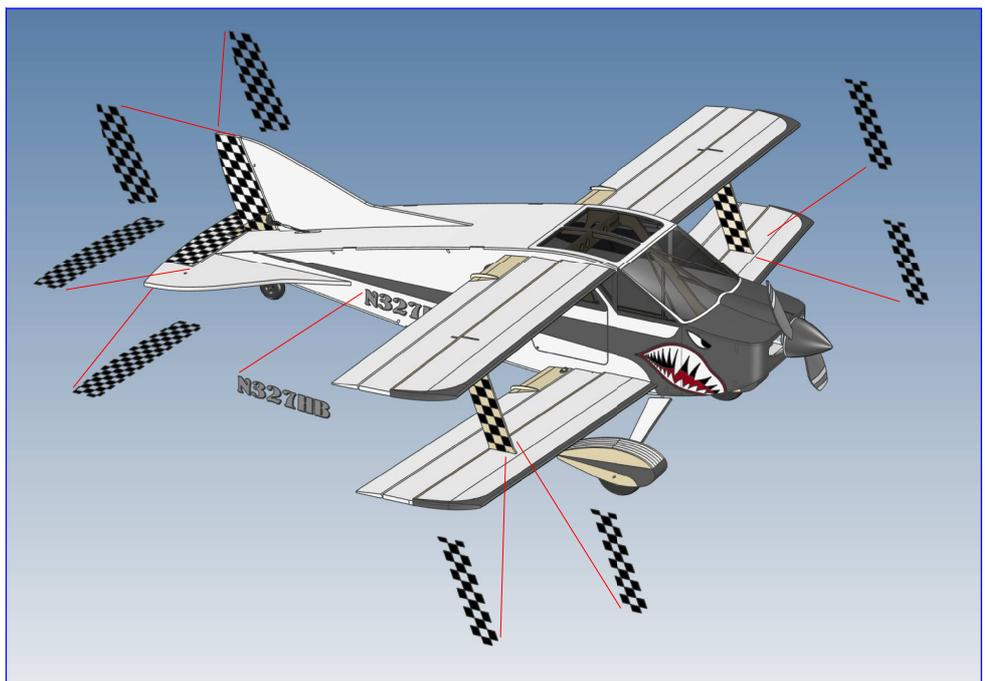



NO
STEP

NO
STEP



POWERED BY
LYCOMING

POWERED BY
LYCOMING

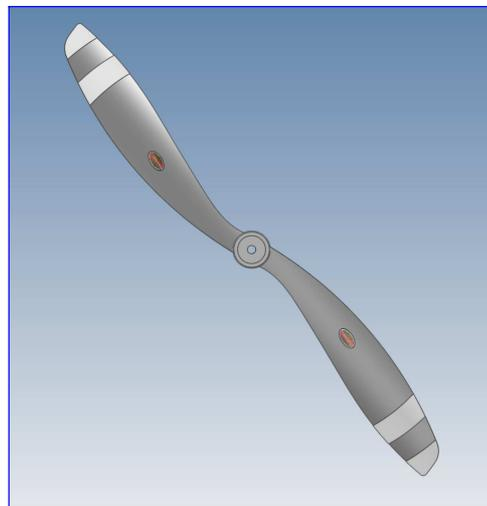
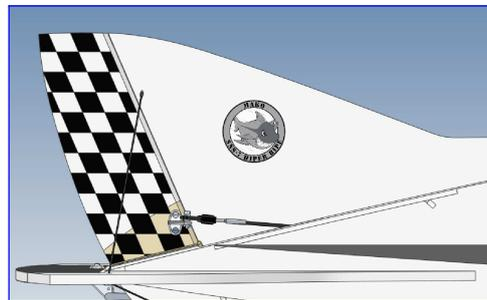
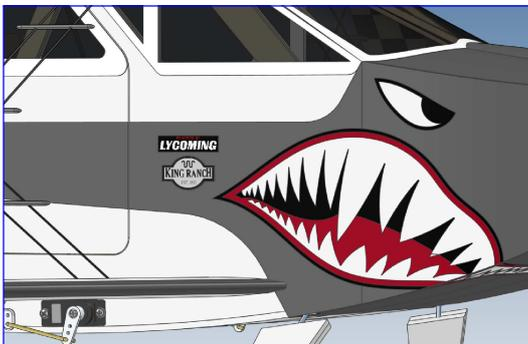

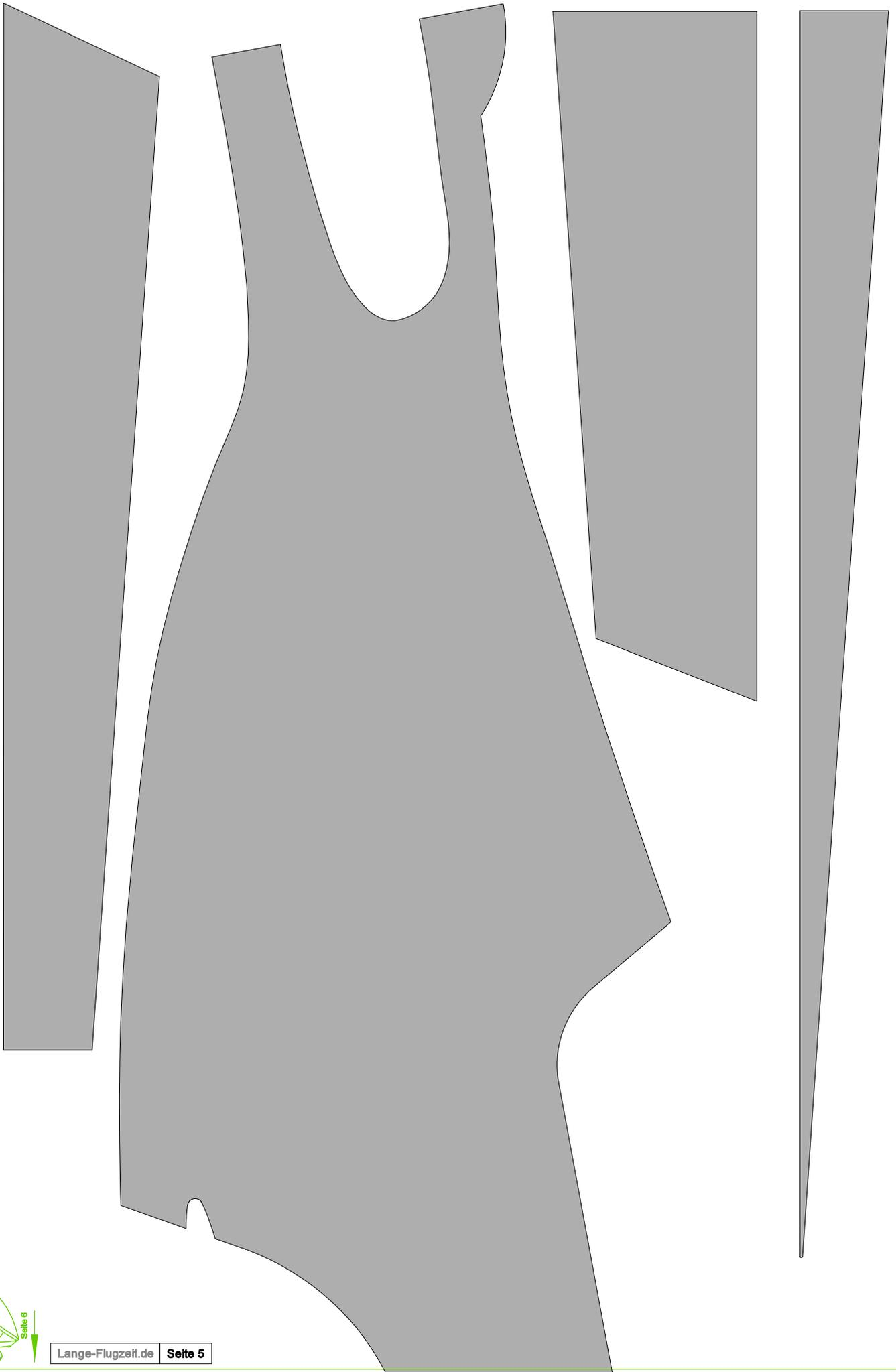

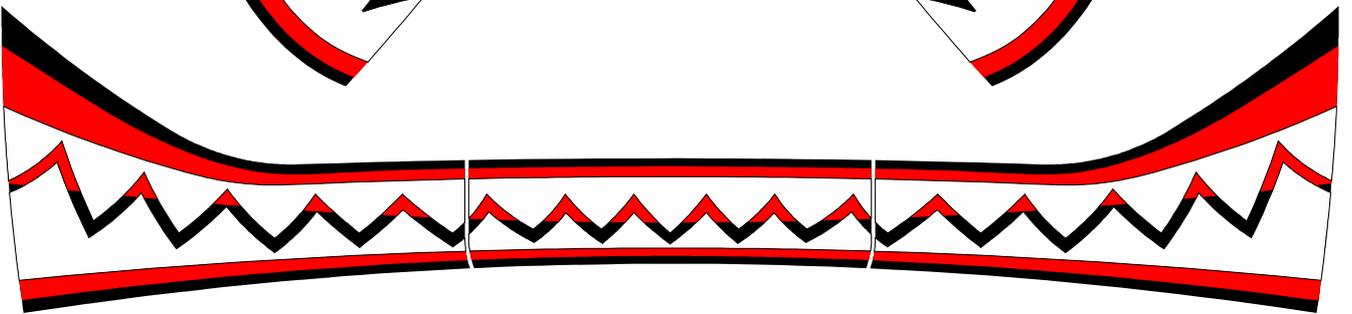
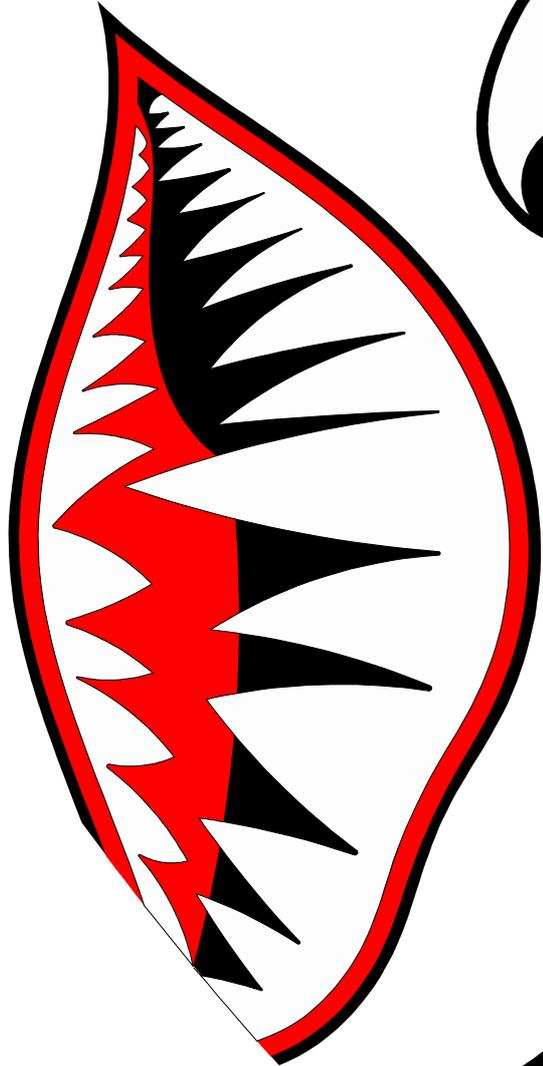
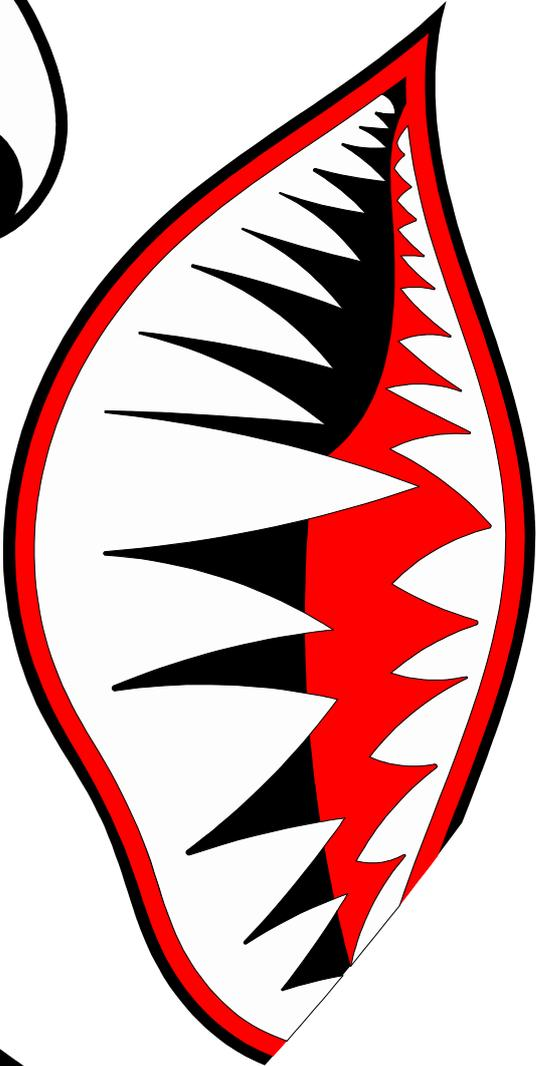
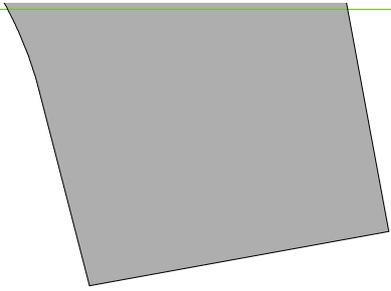

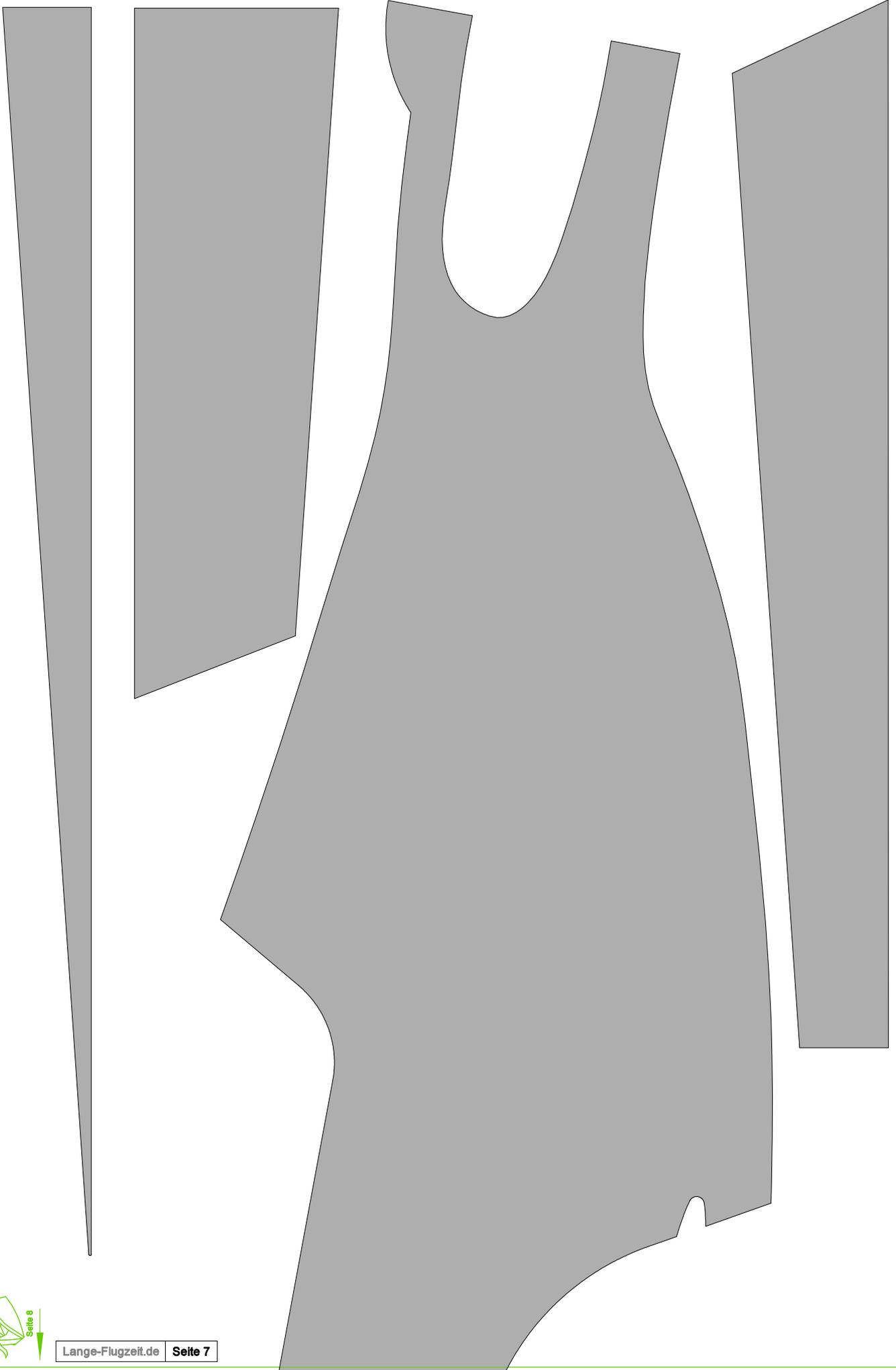

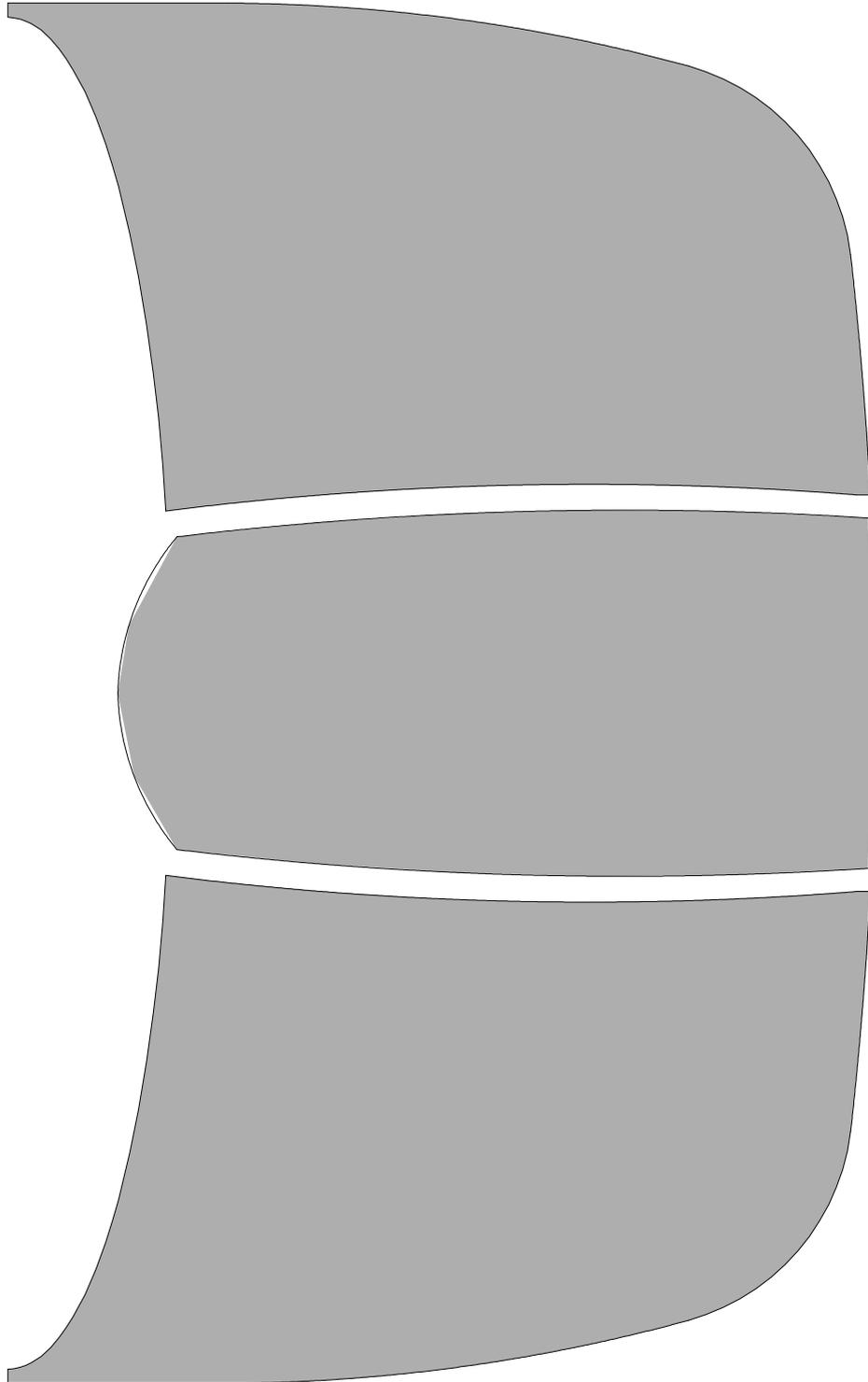
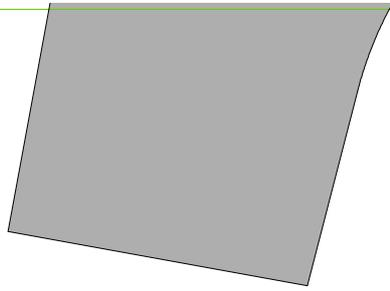

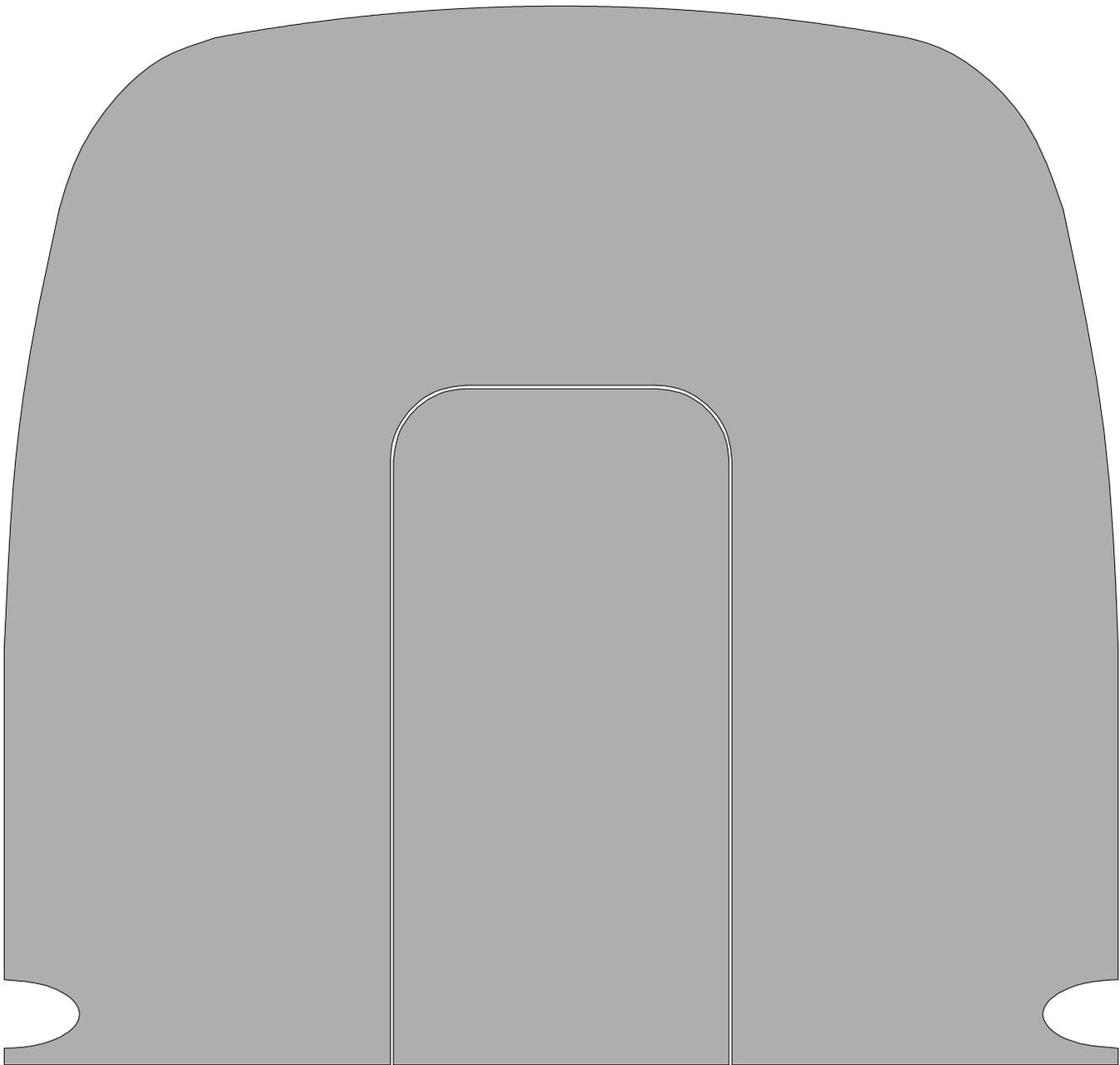

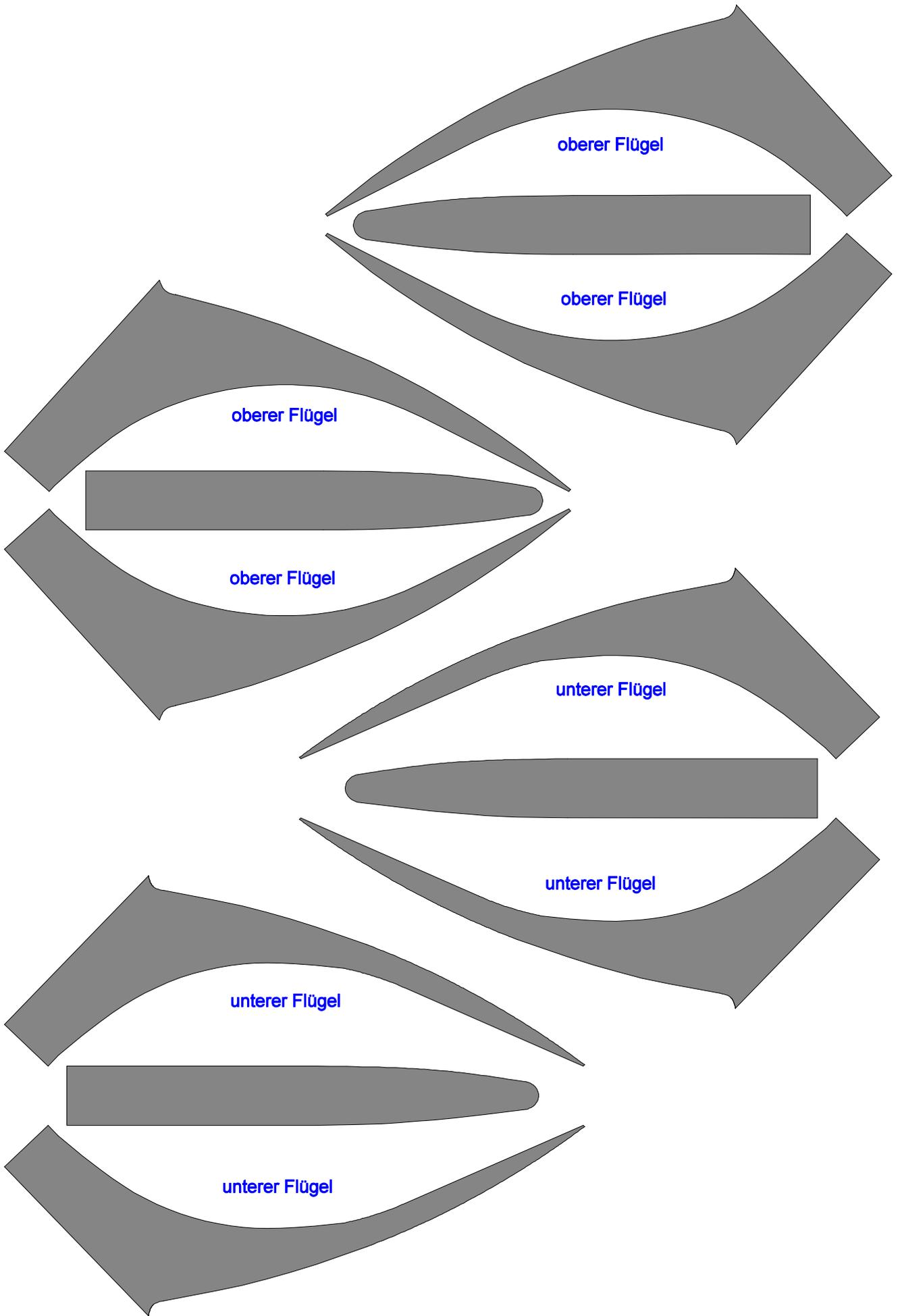

2x schneiden (also insgesamt 16 Streifen)
cut these twice so you get 16 stripes

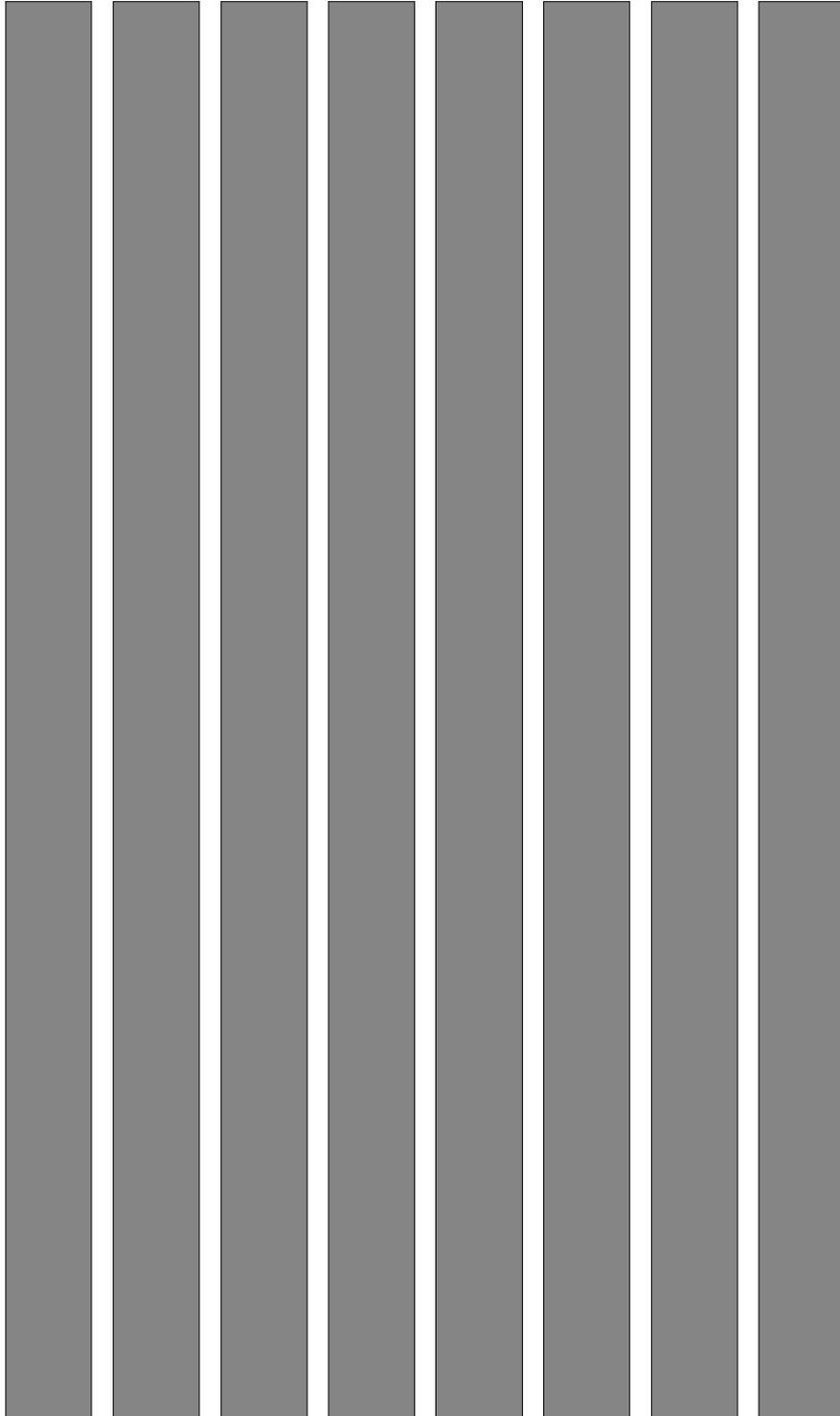

N327HB

N327HB

N327HB

N327HB

